

# **After Sales Technical Documentation NHE-6 Series Transceiver**

## **Chapter 3**

# **TRANSCEIVER OVERVIEW**

## CHAPTER 2 – TRANSCEIVER OVERVIEW

### Contents

Introduction	Page 3-3
Block Diagram of External Connections	Page 3-3
Modes of Operation	Page 3-4
Circuit Description	Page 3-4
Block Diagram	Page 3-5
Power Distribution	Page 3-5
Power Distribution Diagram	Page 3-6

## Introduction

The NHE-6 is a radio transceiver unit for the pan-European GSM network. It is a GSM (phase 2) power class 4 transceiver providing 15 power levels with a maximum output power of 2 W.

The transceiver consists of a Radio module (GJ8A), UI-module (GU8) and assembly parts

The plug-in (small size) SIM (Subscriber Identity Module) card is located inside the phone.

## Block Diagram of External Connections

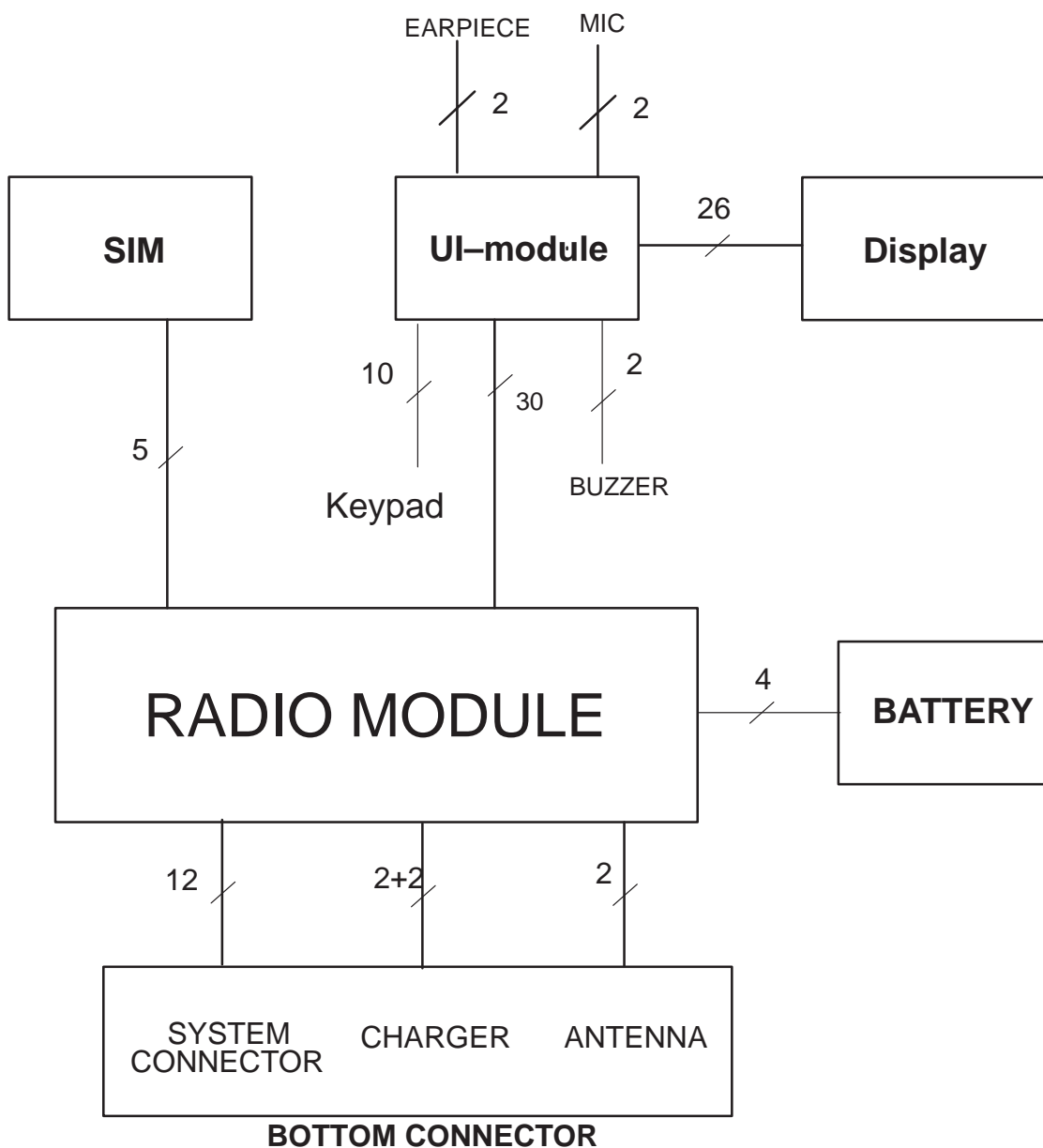

## Modes of Operation

There are four different operation modes

- power off mode
- idle mode
- active mode
- local mode

In the power off mode only the circuits needed for power up are supplied.

In the idle mode circuits are in reset, powered down and clocks are stopped as long as possible.

In the active mode all the circuits are supplied with power although some parts might be in the idle state part of the time.

The local mode is used for alignment and testing.

## Circuit Description

The transceiver electronics consists of the Radio Module (RF + BB blocks), the UI-module and the display module. The UI-module is connected to the Radio Module with a connector and display module is connected to UI-module by solder joint. BB blocks and RF blocks are interconnected with PCB wiring. The Transceiver is connected to accessories via a bottom system connector with charging and accessory control.

The BB blocks provide the MCU and DSP environments, Logic control IC, memories, audio processing and RF control hardware (RFI2). On board power supply circuitry delivers operating voltages for BB blocks. RF blocks have regulators of their own.

The general purpose microcontroller, Hitachi H8/3001, communicates with the DSP, memories and Logic control IC with an 8-bit data bus.

The RF block is designed for a handportable phone which operates in the GSM system. The purpose of the RF block is to receive and demodulate the radio frequency signal from the base station and to transmit a modulated RF signal to the base station.

# Block Diagram

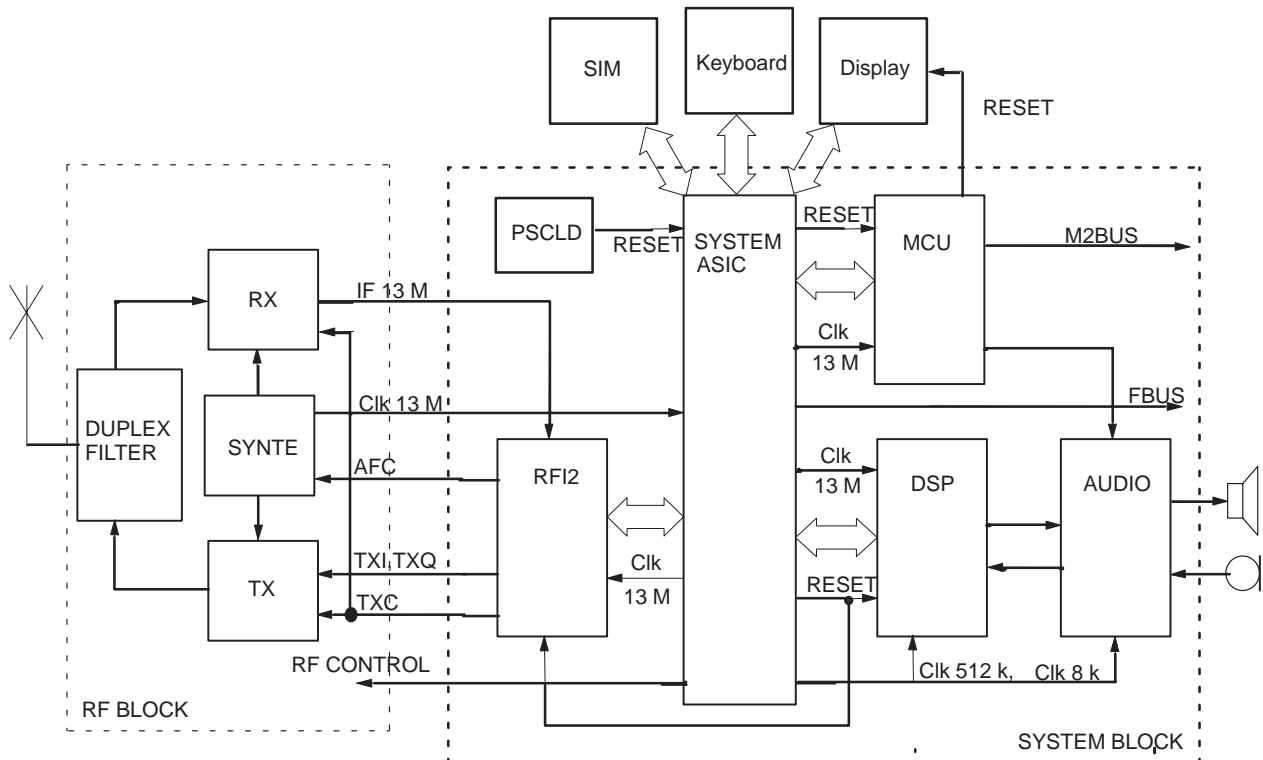

## Power Distribution

The power supply is based on the ASIC circuit PSCLD. The chip consists of regulators and control circuits providing functions like power up, reset and watchdog functions. External buffering is required to provide more current.

The MCU and the PSCLD circuits control charging together, detection being carried out by the PSCLD and higher level intelligent control by the MCU. Charger voltages as well as temperature and size of the battery are measured by internal ADC of MCU or RFI (depending on the state of the phone). MCU measures battery voltage via DSP by means of RFI2 internal ADC.

The detailed power distribution diagrams are given in Baseband blocks and RF blocks documents.

# Power Distribution Diagram

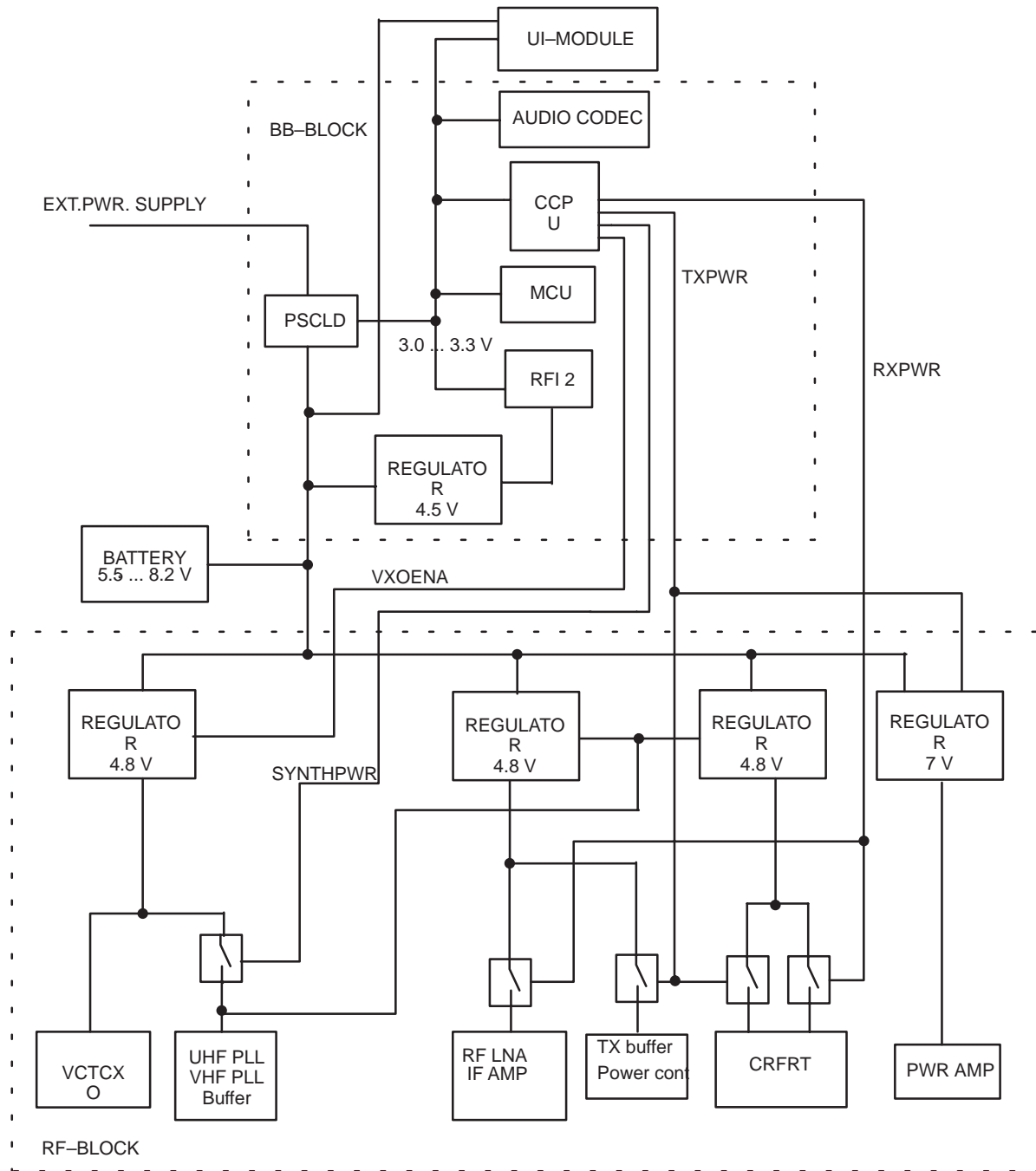

This page intentionally left blank.